

ESTRAIBILI RITORNO A MOLLA

ARTICOLI > 12380 - 12385 - 12681 - 12781 - 14781
17681 - 17781 - 17787

ITEMS > 12380 - 12385 - 12681 - 12781 - 14781
17681 - 17781 - 17787

ATTENZIONE GENERALE >
PRIMA DI ALIMENTARE IL RUBINETTO CON ACQUA, AVERE CURA DI SMONTARE L' AERATORE E FAR DEFLUIRE UNA BUONA QUANTITÀ DI ACQUA (POSSIBILMENTE CALDA) AL FINE DI ESPELLERE L' ECCEDENZA DI GRASSO O IMPURITÀ CHE ANDREBBE AD INTASARE L' AERATORE. SCIACQUARE ACCURATAMENTE LE TUBAZIONI PER ELIMINARE OGNI RESIDUO (SI CONSIGLIA IL MONTAGGIO DI UN RUBINETTO SOTTOLAVABO A FILTRO O FILTRO CENTRALIZZATO).

GENERAL ATTENTION >
WHEN MIXER'S IS INSTALLED, PLEASE REMOVE AERATOR BEFORE RUNNING THE WATER THE FIRST TIME AND LET A GOOD QUANTITY OF WARM WATER RUN THROUGH SO TO EXPELL EXCESS OF LUBRICATING GREASE OR OTHER IMPURITIES THAT MAY STICK IN THE AERATOR. BEFORE THE INSTALLATION PLEASE MAKE SURE TO LET SOME WATER RUN FORM THE PIPES TO REMOVE POSSIBLE DEBRIS (WE SUGGETS TO INSTALL A FILTER STOP COCK).

IMPORTANTE FORO CERAMICA >
DIAMETRO MINIMO 34 MM
DIAMETRO MASSIMO 37 MM

IMPORTANT CERAMIC HOLE >
DIAMETER MINIMUM 34 MM
DIAMETER MAXIMUM 37 MM

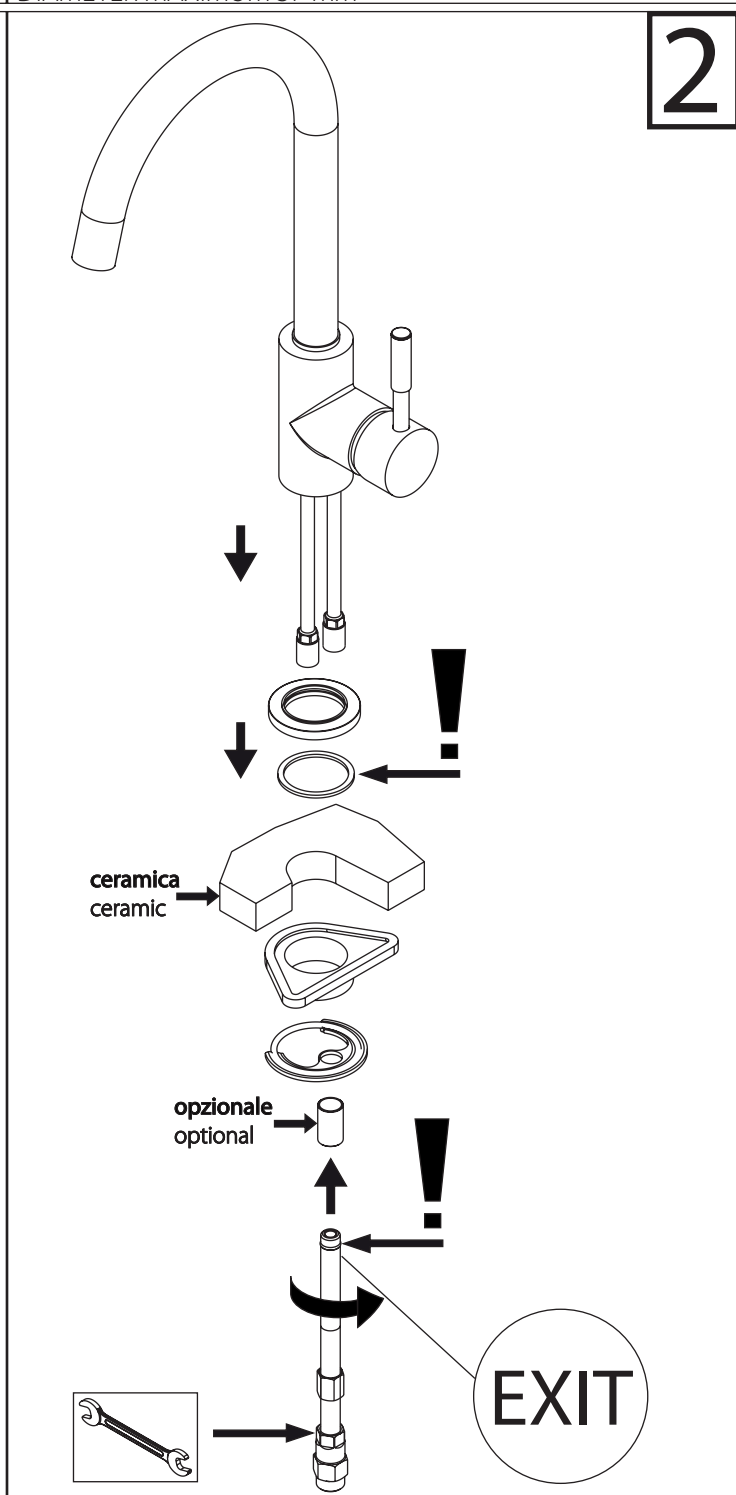
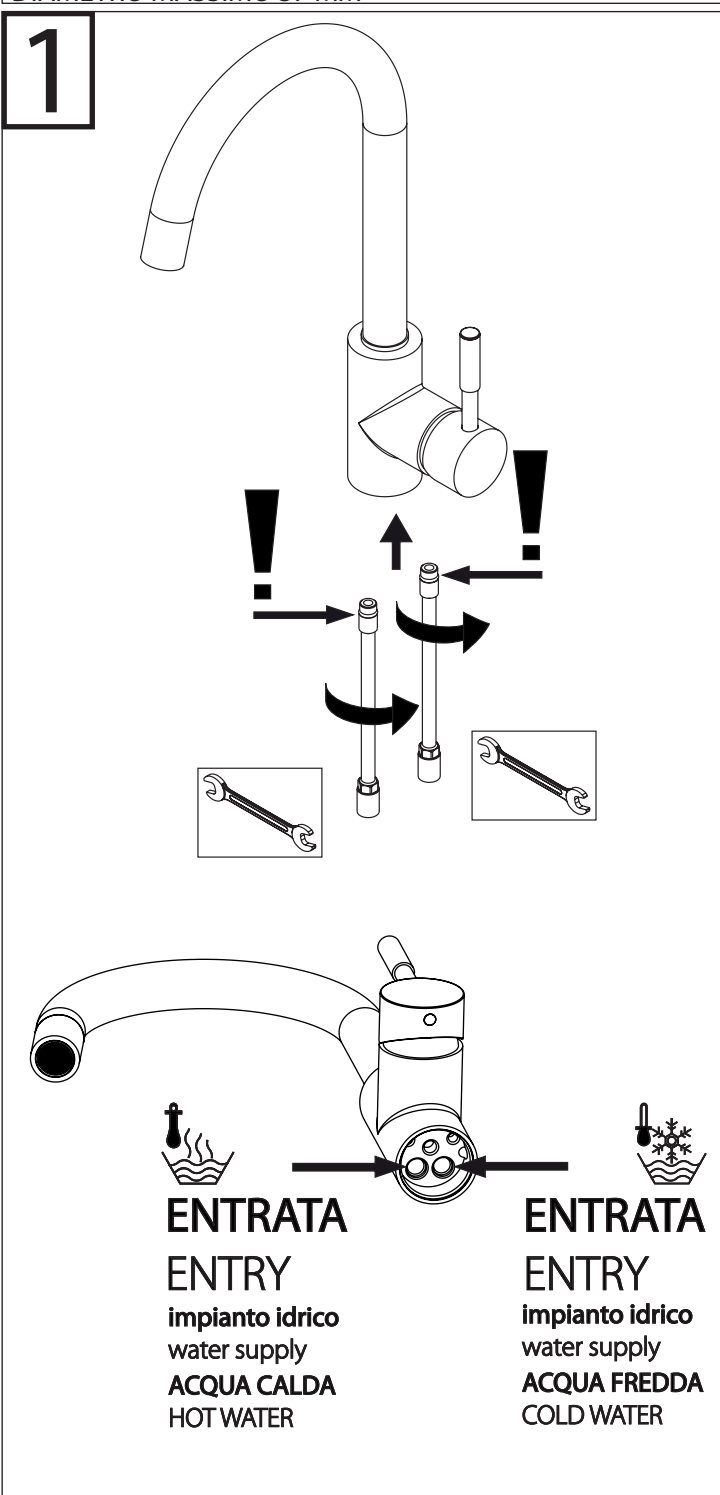

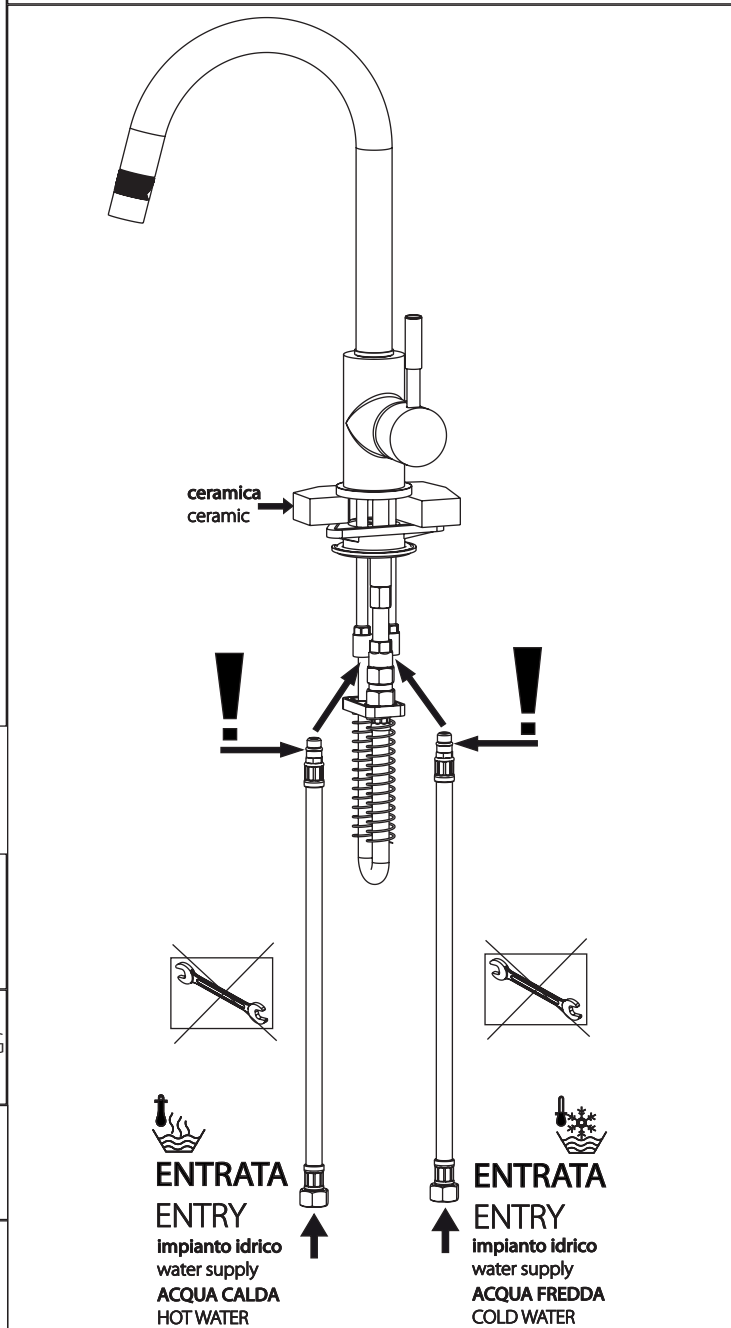
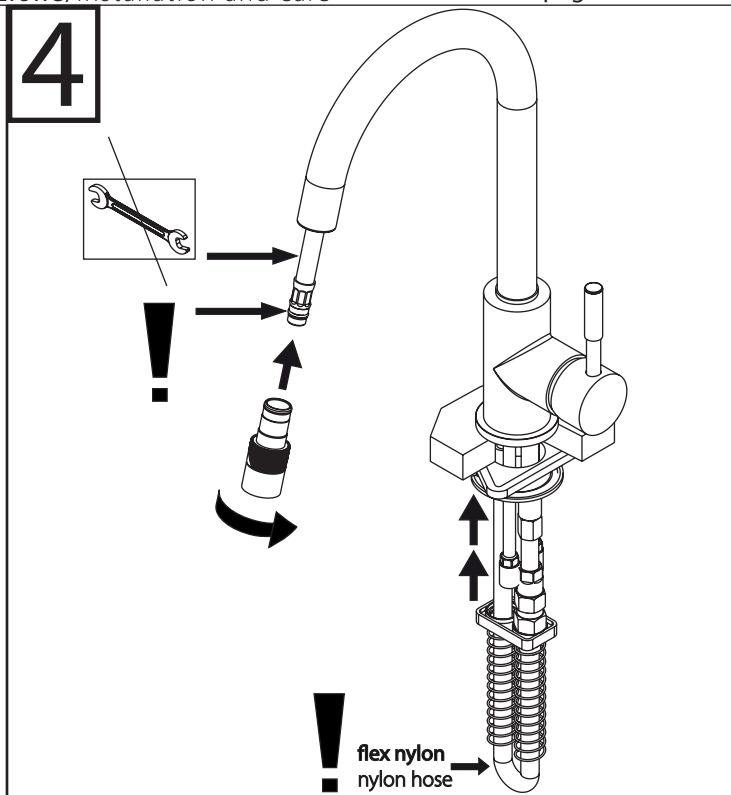
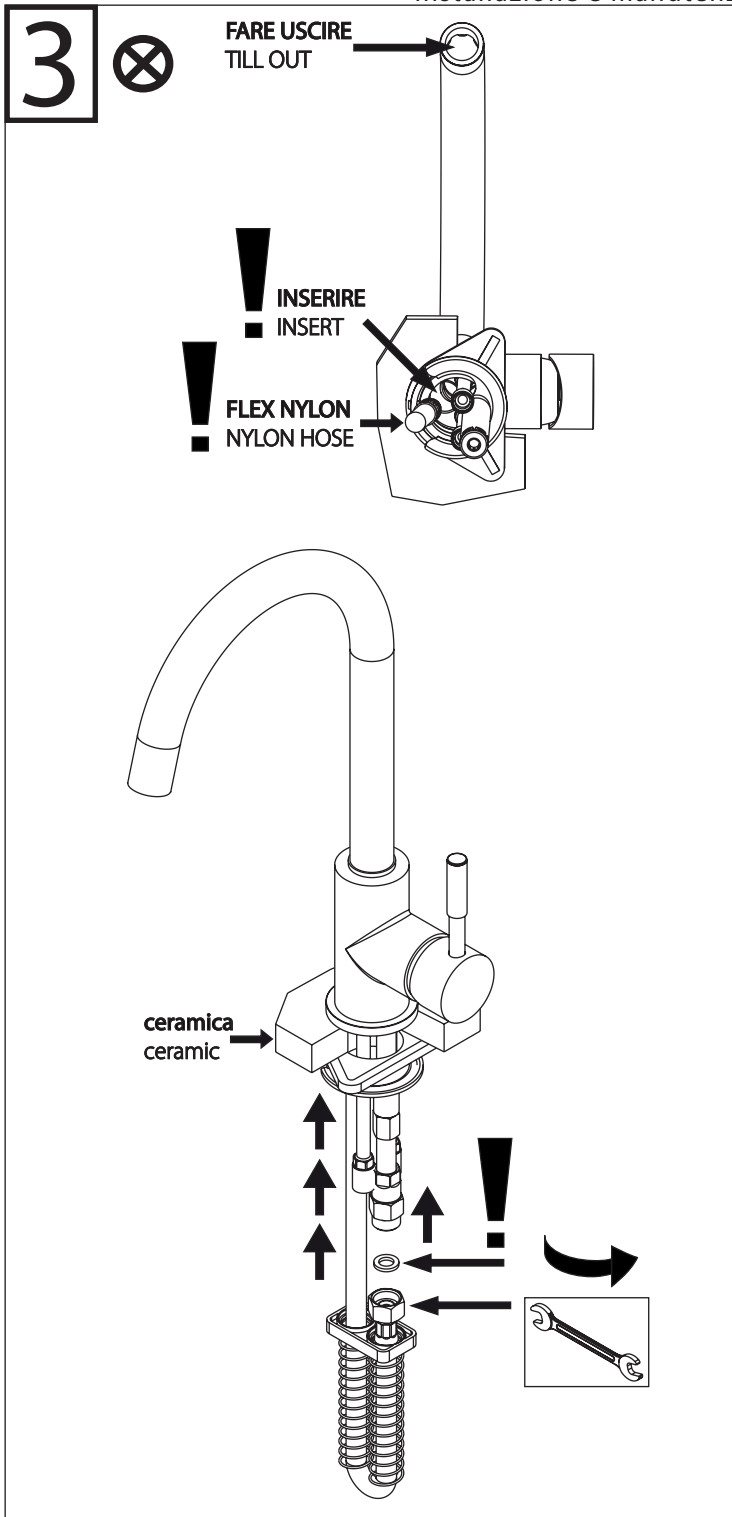

ATTENZIONE

PRENDERE IL SACCHETTO CON IL FLESSIBILE E MOLLA ED ESTRARRE IL CONTENUTO FACENDO ATTENZIONE A NON FAR SFILARE IL FLESSIBILE DALLA MOLLA

ATTENTION

TAKE OUT PLASTIC BELT FLEXIBLE HOSE WITH SPRING BEING CAREFUL NOT LET THE SPRING SLIDE OUT THE FLEXHOSE

ATTENZIONE

POSIZIONARE IL FERMO-MOLLA IN MODO CHE NON INTERFERISCA CON I FLEX INOX E FLEX NYLON

ATTENTION

LOCATE THE SPRING STOPPER SO THAT IT DOES NOT DISTURB THE MOVEMENT OF THE FLEXIBLE AND NYLON HOSE

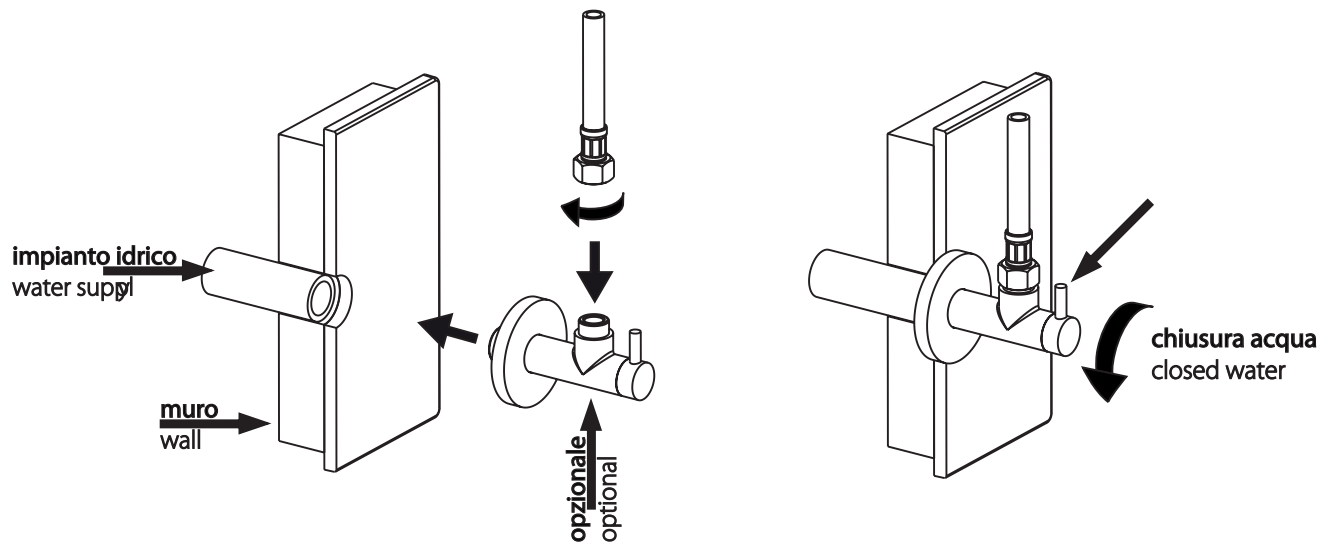

INFORMAZIONI IMPORTANTI ATTACCHI FLEX INOX
IMPORTANT INFORMATION FLEX-HOSE CONNECTIONS
WICHTIGE HINWEISE FÜR DIE VERWENDUNG DER ELASTISCHEN SCHLAUCHVERBINDUNGEN

Prima dell'installazione controllare la presenza e l'integrità delle graffiature da ambo i lati.

Before assembling the hose, please check the appropriate crimping.

Überprüfen Sie vor der Montage des Schlauchs die dazugehörigen Dichtungen und Muttern.

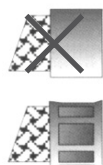

Non installare il flessibile in torsione o in tensione.

Tighten the hose without any twist or tension.

Befestigen Sie den Schlauch ohne Gewalt und ohne Drehung.



Dopo il montaggio evitare sollecitazione laterali anche minime, con qualsiasi utensile. (Es. durante il fissaggio del tirante o dell'astina).

Do not expose the hose to lateral stress nor overtight by any tool. (Ex. during the installation of the faucet stud or the drain pop-up lever). Setzen Sie den Schlauch weder seitlicher Belastung noch zu großer Spannung durch irgendein Werkzeug aus. (Außer bei der Montage)



Non incassare il condotto nel muro.

Do not set the hose in the wall. Setzen Sie den Schlauch nicht in die Wand ein.



Avvitare i raccordi con tenuta oring a mano coppia massima di serraggio 3 Nm.

Hand-tighten oring seal connectors max torque 3 Nm Dichtungsanschlüsse handfest anziehen mit einem maximalen Drehmoment von 3 Nm.



Non serrare con utensili non adatti o in punti non corretti.

Do not tighten by inappropriate tools or in inappropriate ways.

Benutzen Sie keine ungeeigneten Methoden oder Werkzeuge zur Befestigung.



Avvitare i raccordi con tenuta a guarnizione (dadi) a mano più 1/4 di giro con chiave appropriata.

Hand-tighten connectors with gasket seal (nuts) the apply 1/4 turn using an appropriate wrench.

Verbinden Sie das Anschlussstück handfest mit der Dichtung (Mutter) durch eine 1/4 Drehung.

Verwenden Sie dafür einen passenden Schraubenschlüssel.

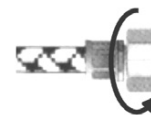

Il contatto prolungato con sostanze, pur blandamente aggressive, può determinare il danneggiamento della treccia ed il conseguente scoppio del flessibile.

Prolonged contact with any substance, even scarcely aggressive, can cause external braid damage and subsequent flexible burst.

Längerer Kontakt mit jeglicher Substanz, sogar nur leicht aggressiver, kann zur äußerlichen Beschädigung des Schutzgeflechts führen und in Folge dessen zur Bruchigkeit des flexiblen Bauteils.



DN6=25 mm DN8=30 mm
 DN10=35 mm DN13=45 mm



Rispettare il raggio minimo di curvatura.

Maintain minimum bend radius.

Aufrechterhaltung des minimalen Biegungsradius:



Prima dell'inizio della curvatura lasciare un tratto rettilineo di almeno 1.5 - 2 volte il diametro esterno.

Before bending the hose please consider a straight part of at 1.5 - 2 times the external diameter.

Bevor sie den Schlauch biegen berücksichtigen Sie bitte ein gerades Stück von mindestens 1,5 bis 2 facher Länge des äußeren Durchmessers.



Non collegare la messa a terra dell'impianto elettrico al flessibile o ad altra condotta idraulica. Chiudere l'impianto idraulico in caso di prolungata assenza. Sostituire il flessibile in caso di piccole perdite e comunque entro i termini di garanzia.

Do not connect the electric grounding to the flexible hose nor to any other water piping. Turn off the plumbing in case of long absence.

Replace the hose in case of leakage and anyway, always before the guarantee expiration.

Verbinden Sie niemals die elektrische Erdung mit dem flexiblen Schlauch oder jedem anderen Wasserrohr. Bitte stellen Sie das Wasser bei längerer Abwesenheit ab. Ersetzen Sie den Schlauch im Falle eines Lecks und grundsätzlich immer bevor die Mindesthaltbarkeit abläuft.



SEGUIRE LE INFORMAZIONI DOVE VIENE INDICATO IL SIMBOLO
 TO FOLLOW THE INFORMATION WHERE COMES INDICATING THE SYMBOL

modulo 0/section 0:
info importanti/important information

12380

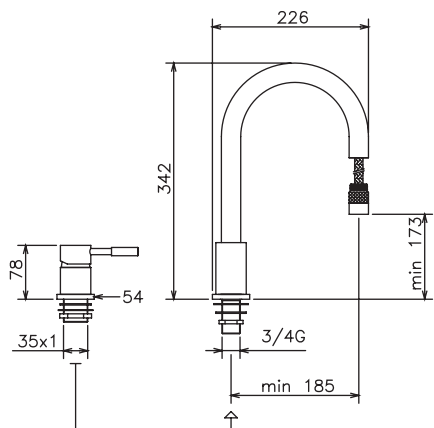

12385

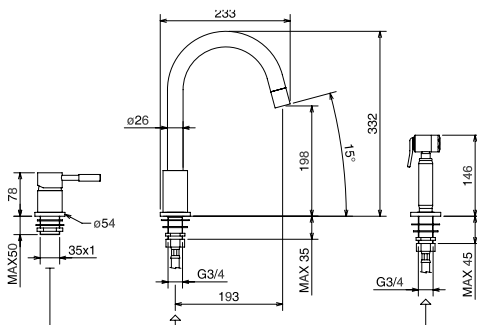

12681

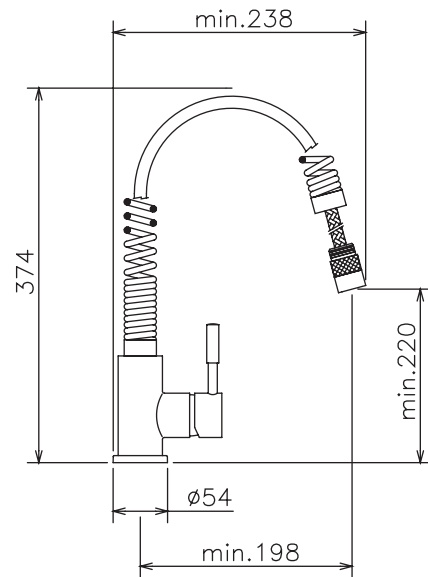

12781

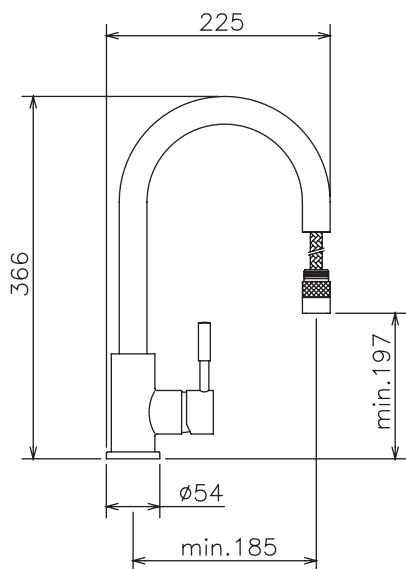

17681

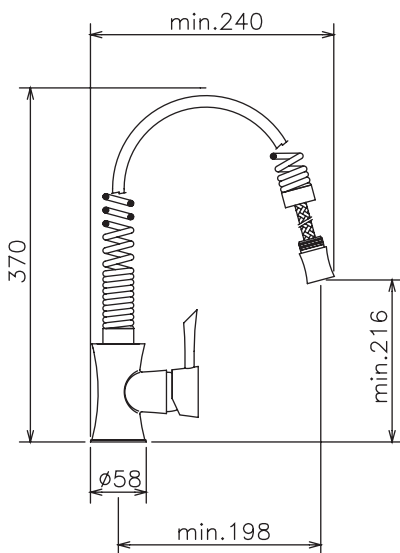

17781

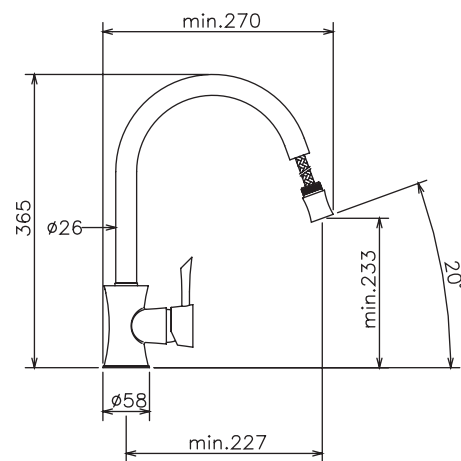

17787

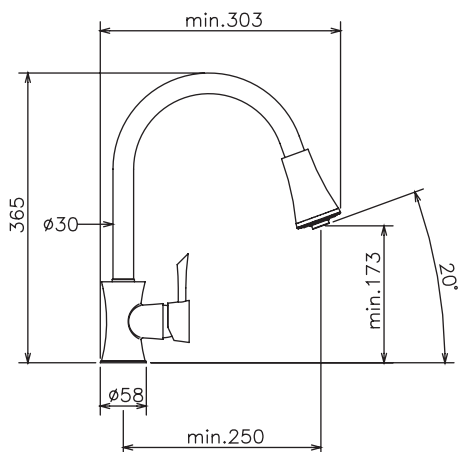

14781

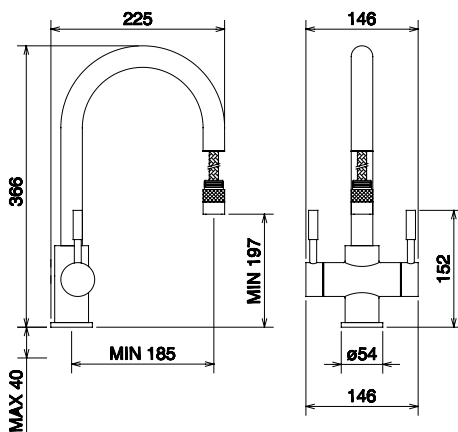

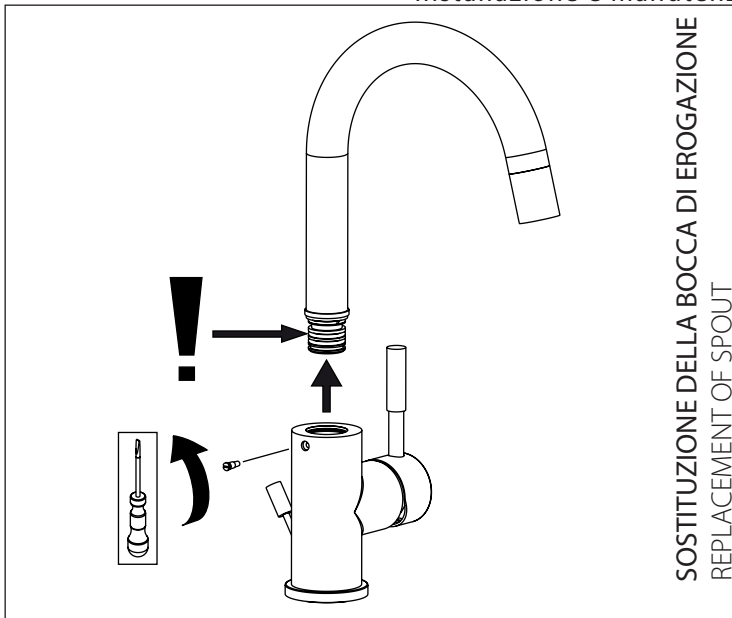

SOSTITUZIONE DELLA BOCCA DI EROGAZIONE
REPLACEMENT OF SPOUT

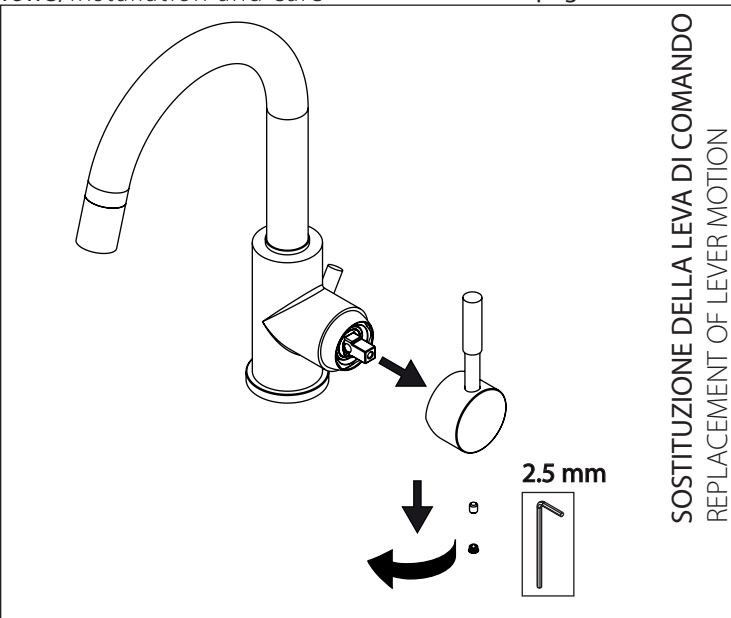

SOSTITUZIONE DELLA LEVA DI COMANDO
REPLACEMENT OF LEVER MOTION

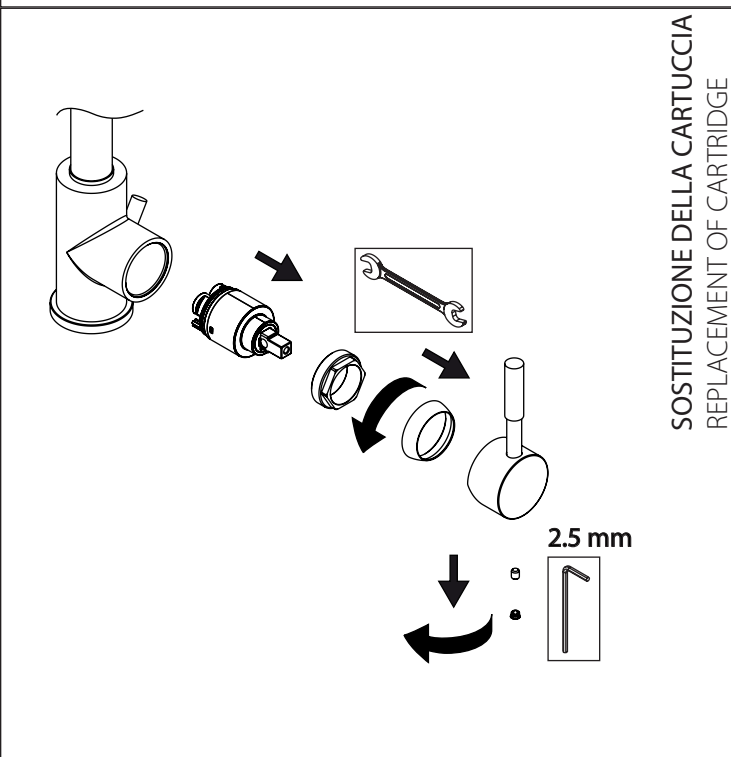
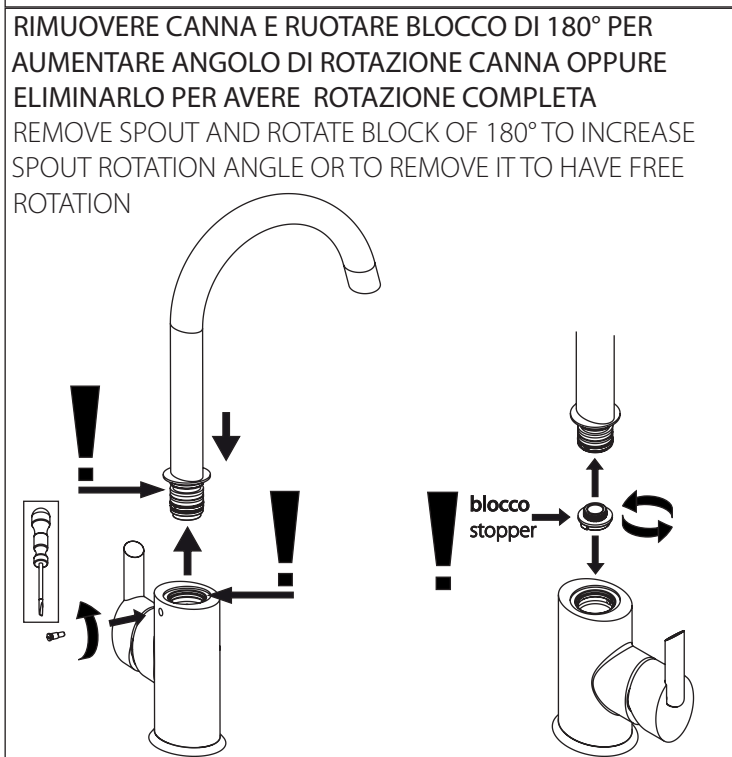

SOSTITUZIONE DELLA CARTUCCIA
REPLACEMENT OF CARTRIDGE

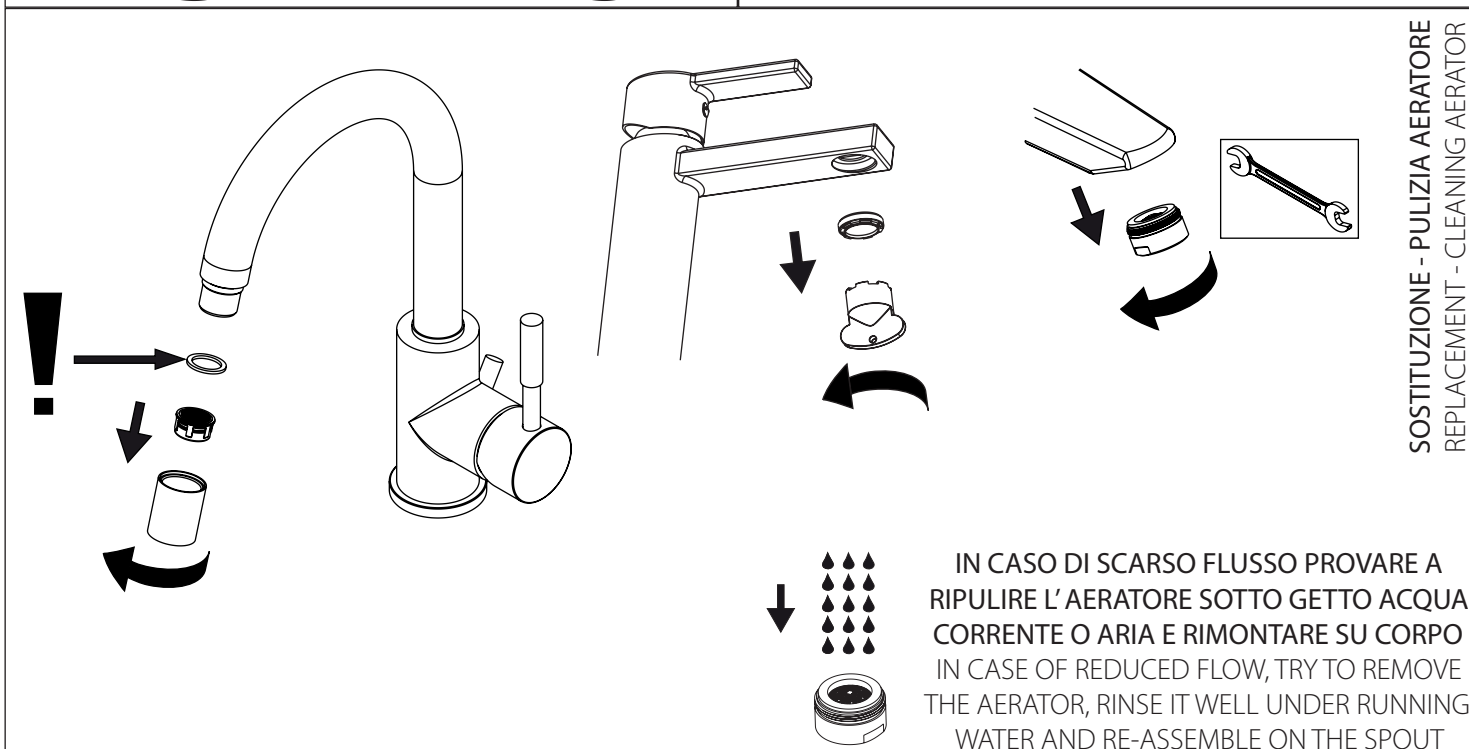

SOSTITUZIONE - PULIZIA AERATORE
REPLACEMENT - CLEANING AERATOR

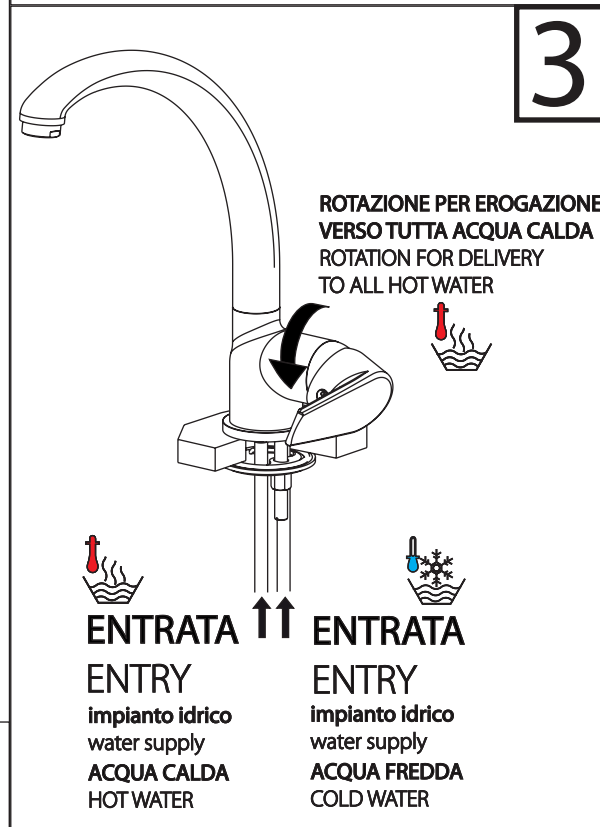
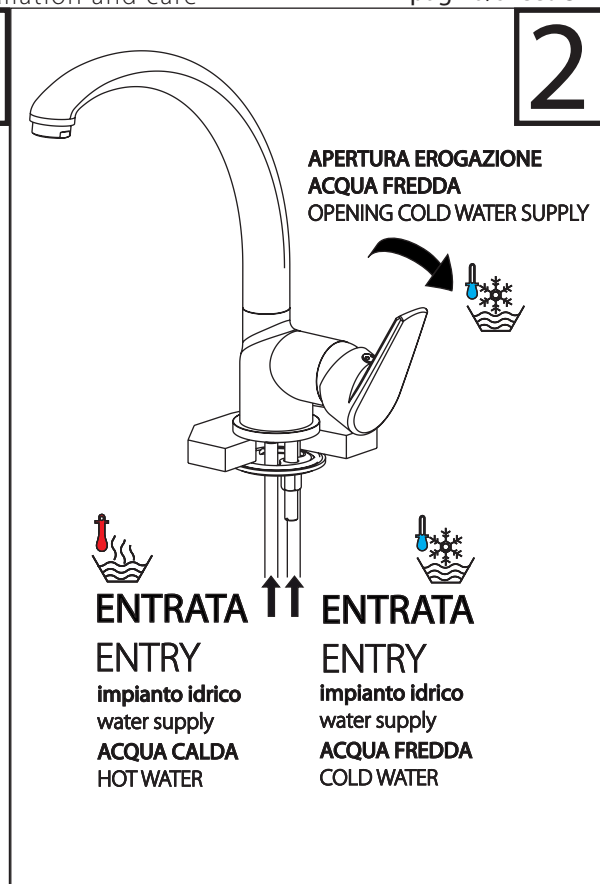
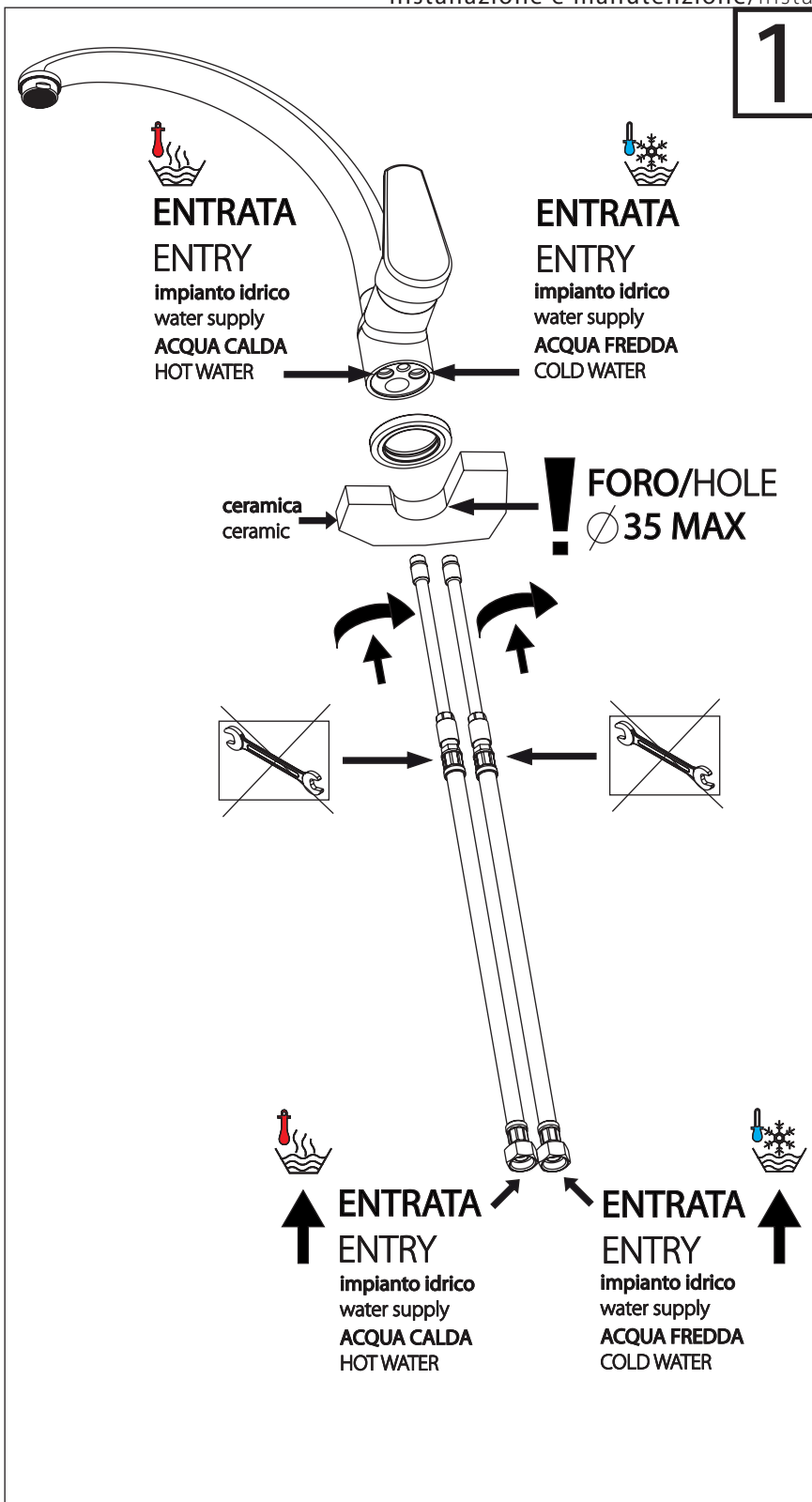

CARTUCCIA 90° APERTURA
IN POSIZIONE ACQUA FREDDA
RISPARMIO ENERGETICO

CARTRIDGE 90°
OPEN IN COLD POSITION
ENERGY SAVING

CARTUCCIA CON APERTURA IN POSIZIONE ACQUA FREDDA:
> ACQUA CALDA = CONSUMO ENERGETICO
> POSIZIONE NORMALE LEVA CENTRALE CON EROGAZIONE DI ACQUA FREDDA, MISCELAZIONE A DESTRA. VERSO LA MASSIMA TEMPERATURA SOLO QUANDO SERVE.

CARTRIDGE WITH OPEN POSITION COLD WATER:
> HOT WATER = ENERGY CONSUMPTION
> NORMAL POSITION LEVER IN THE MIDDLE SUPPLYING COLD WATER MIXING TURNING TO THE RIGHT FOR LUKEWARM TO HOT WATER ONLY WHEN NEEDED.

ATTENZIONE
SMONTARE DOCCETTA E SFILARE IL FLEX NYLON
SVITARE IL FLEXNYLON DAL TIRANTE E SOSTITUIRE

ATTENTION
REMOVE SHOWER HEAD AND THE FLEX NYLON
UNSCREW THE FLEXNYLON FROM THE ROD AND REPLACE

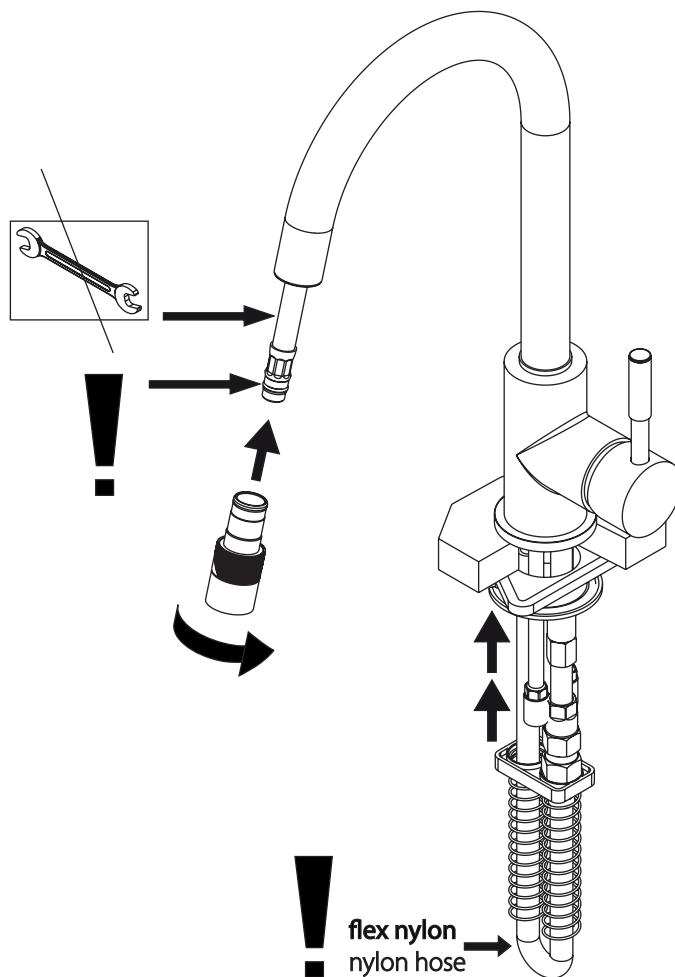

RIPRENDERE IL MONTAGGIO DAL PUNTO 4
PROCEED WITH THE ASSEMBLY FROM POINT 4

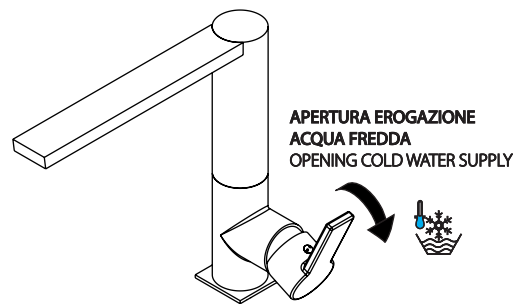
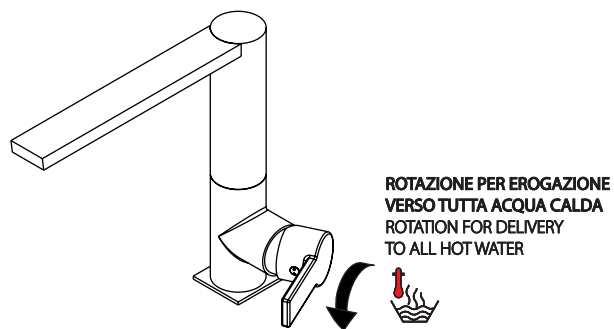

- > MONOCOMANDO CON CARTUCCIA A 90° A COMANDO LATERALE, APERTURA IN POSIZIONE DI ACQUA FREDDA
- > MIXER WITH 90° CARTRIDGE WITH SIDE LEVER, OPEN IN COLD POSITION

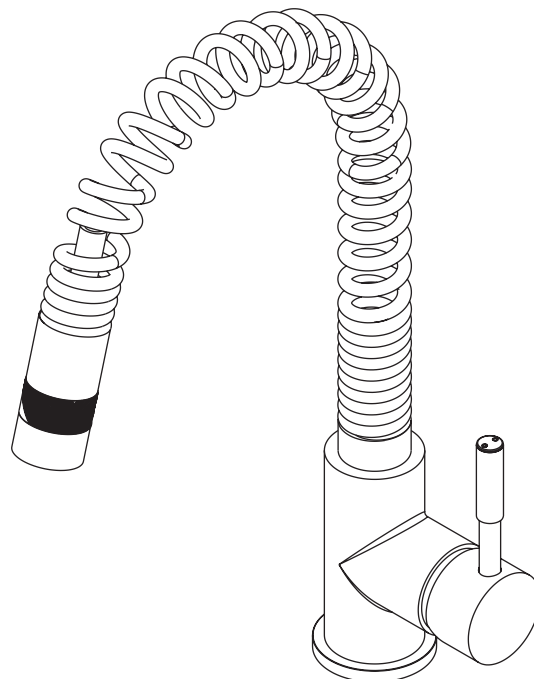
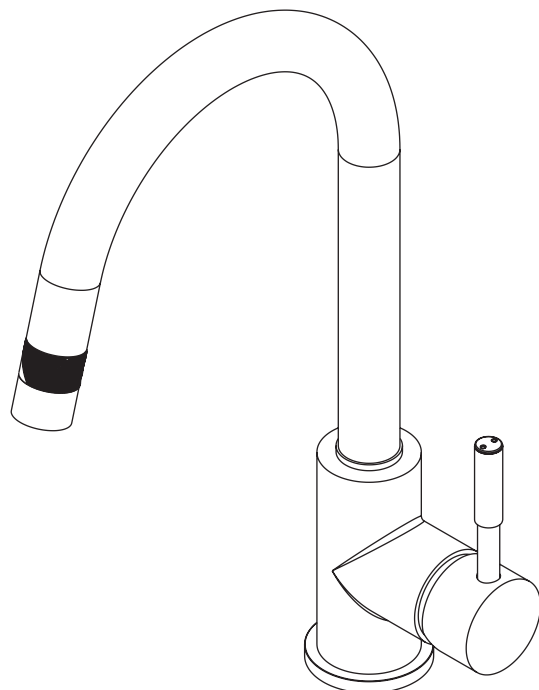

DOMANDE E RISPOSTE / FAQ

GUASTO >	CAUSA >	SOLUZIONE POSSIBILE >
SCARSITA' D' ACQUA	FILTRO AERATORE INTASATO DOCGETTA CON GETTI INTASATI FLESSIBILI COLLEGATI NON BENE	PULIRE AERATORE O SOSTITUIRLO PULIRE GETTI DOCGETTA CON UN DITO RIFARE IL COLLEGAMENTO DEI FLESSIBILI
MISCELATORE DURO	CARTUCCIA DIFETTOSA	SOSTITUIRE LA CARTUCCIA
MISCELATORE GOCCIOLA	CARTUCCIA DIFETTOSA	SOSTITUIRE LA CARTUCCIA
PROBLEM >	POSSIBLE REASON >	ACTION >
INSUFFICIENT FLOW	DEBRITS OR LIMESTONE IN AERATOR HANDSHOWER NOOZLE STUCK OR CLOSED SUPPLY HOSES NON CONNECTED	REMOVE AND REPLACE AERATOR CLEAN THE SHOWER NOOZLES BY RUBBING THEM WITH FINGERS DISCONNECT AND CONNECT AGAIN
LEVER HARD TO OPERATE	DEFECTIVE CARTRIDGE	REPLACE CARTRIDGE
LEAKAGE	DEFECTIVE CARTRIDGE	REPLACE CARTRIDGE

SMALTIMENTO DEL PRODOTTO >
 NON DISPERDERE NELL' AMBIENTE PER IL CORRETTO SMALTIMENTO DEL PRODOTTO, FARE RIFERIMENTO ALLA
 NORMATIVA VIGENTE NEL PAESE IN CUI SI VIVE. CONTATTARE LA DISCARICA PIU' VICINA PER MAGGIORI INFORMAZIONI.
 DISPOSAL OF THE ITEM >
 NOT DISPERSE IN NATURE FOR A CORRECT DISPOSAL OF THE ITEM, PLEASE REFER TO THE SPECIFIC RULES OF YOUR COUNTRY
 THE APPOINTED OFFICE IN YOUR AREA FOR DETAILS.

> MONTAGGIO, USO E MANUTENZIONE - LEGGERE ATTENTAMENTE PRIMA DELL'INSTALLAZIONE - CONSERVARE
> ASSEMBLY, USE AND MAINTENANCE INSTRUCTIONS - READ CAREFULLY BEFORE INSTALLING - TO PRESERVE