

# TOWERTECH LAVABO INC

ARTICOLI > 12200 - 12144

FINITURE > CROMO - FINITURA ACCIAIO

ITEMS > 12200 - 12144

FINISHING > CHROME - FIN. INOX

**ATTENZIONE GENERALE >**

PRIMA DI ALIMENTARE IL RUBINETTO CON ACQUA, AVERE CURA DI SMONTARE L' AERATORE E FAR DEFLUIRE UNA BUONA QUANTITÀ DI ACQUA (POSSIBILMENTE CALDA) AL FINE DI ESPELLERE L' ECCEDENZA DI GRASSO O IMPURITÀ CHE ANDREBBE AD INTASARE L' AERATORE. SCIACQUARE ACCURATAMENTE LE TUBAZIONI PER ELIMINARE OGNI RESIDUO (SI CONSIGLIA IL MONTAGGIO DI UN RUBINETTO SOTTOLAVABO A FILTRO O FILTRO CENTRALIZZATO).

**GENERAL ATTENTION >**

WHEN MIXER'S IS INSTALLED, PLEASE REMOVE AERATOR BEFORE RUNNING THE WATER THE FIRST TIME AND LET A GOOD QUANTITY OF WARM WATER RUN THROUGH SO TO EXPELL EXCESS OF LUBRICATING GREASE OR OTHER IMPURITIES THAT MAY STICK IN THE AERATOR. BEFORE THE INSTALLATION PLEASE MAKE SURE TO LET SOME WATER RUN FORM THE PIPES TO REMOVE POSSIBLE DEBRIS (WE SUGGETS TO INSTALL A FILTER STOP COCK).

**ATTENZIONE >**

NON ECCEDERE NELLE DIMENSIONI DI SCASSO

**WARNING >**

DO NOT EXCED IN THE BREAKING DIMENSIONS

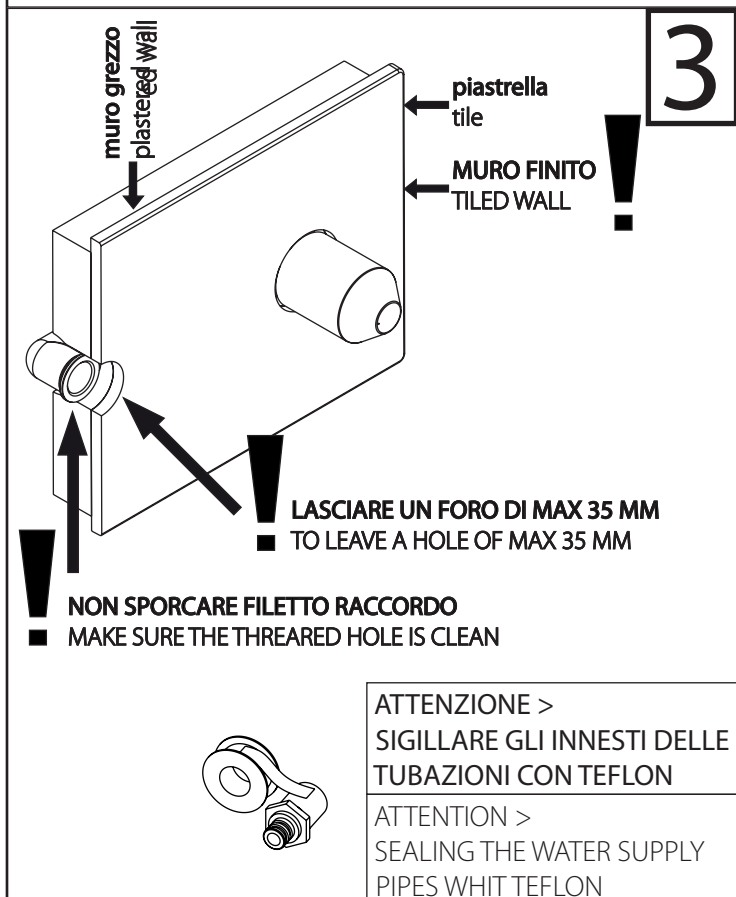
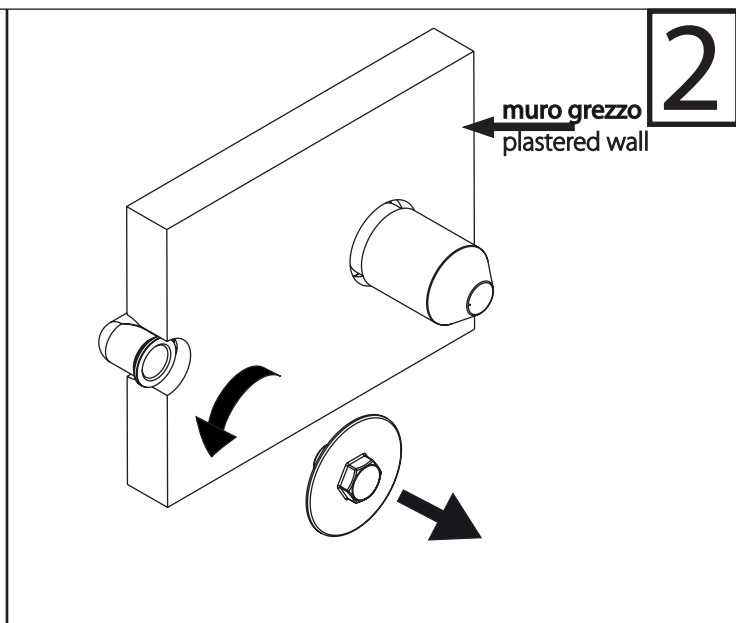
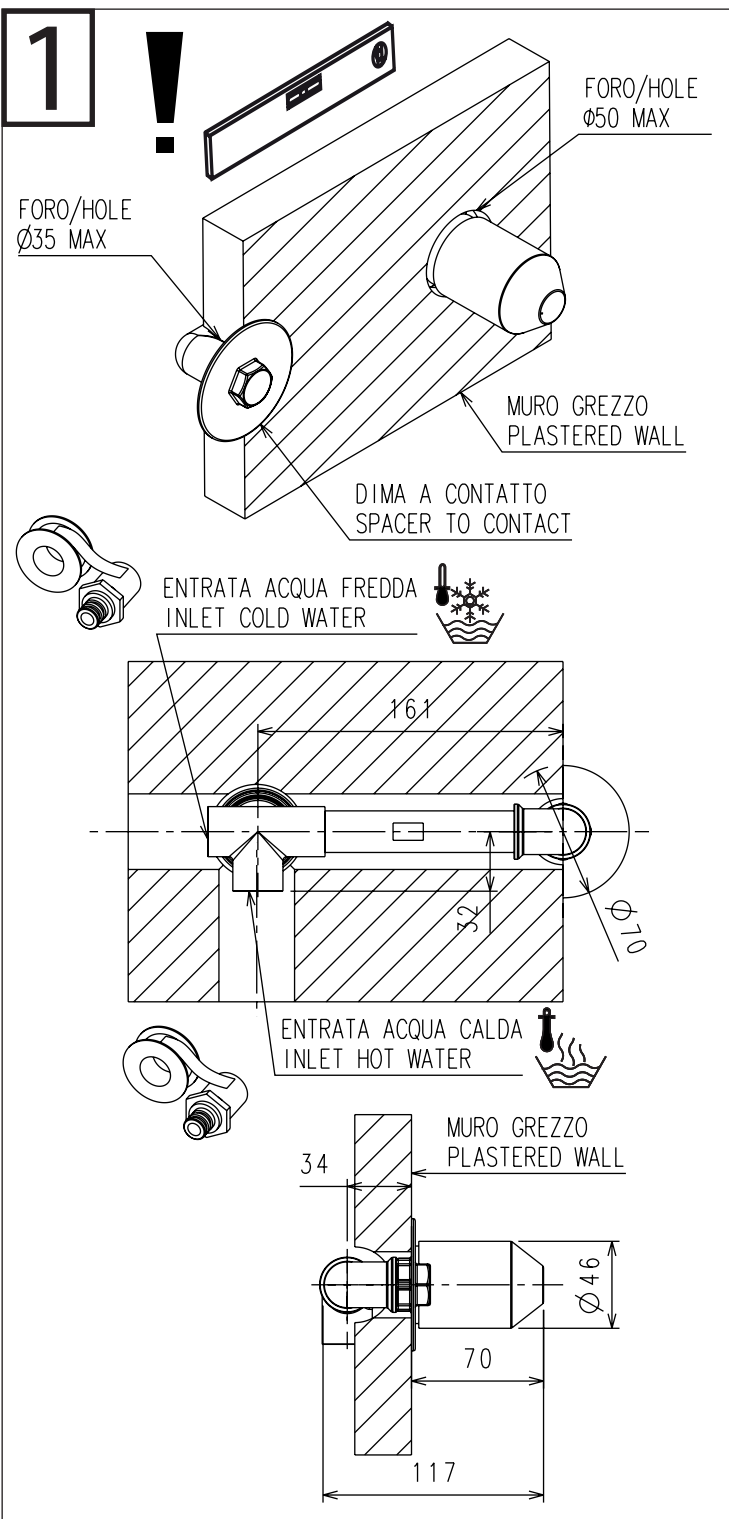

**ATTENZIONE >**  
SIGILLARE GLI INNESTI DELLE TUBAZIONI CON TEFLON

**ATTENTION >**  
SEALING THE WATER SUPPLY PIPES WITH TEFLON

4

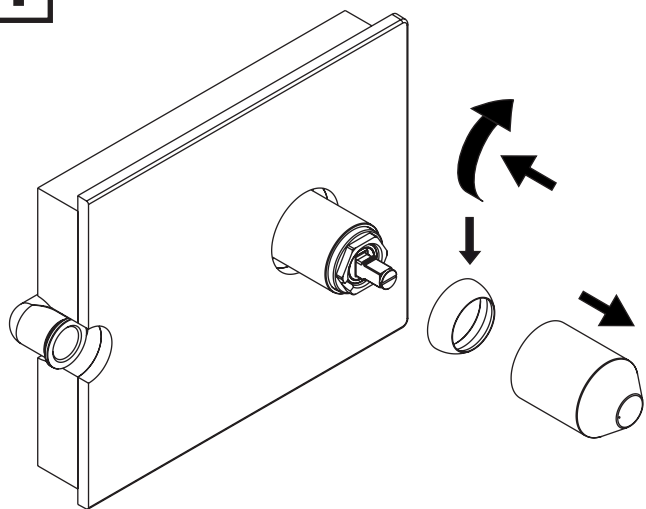

5

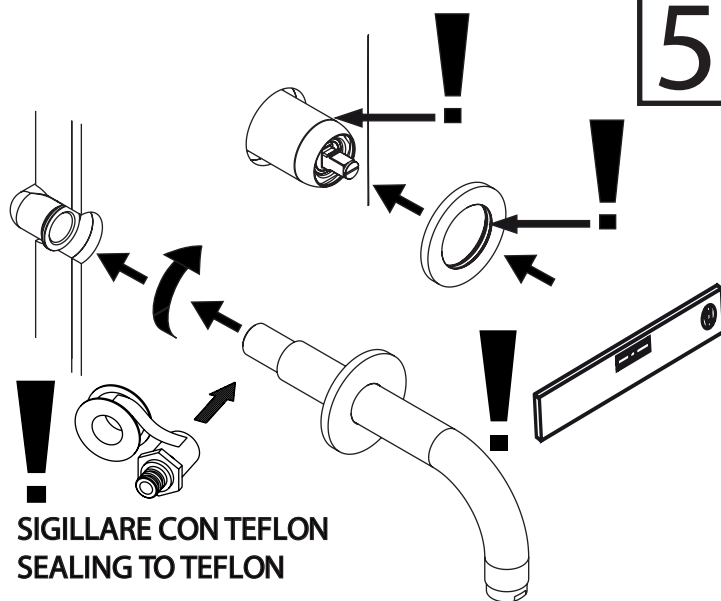

**SIGILLARE CON TEFLON**  
**SEALING TO TEFLON**

6

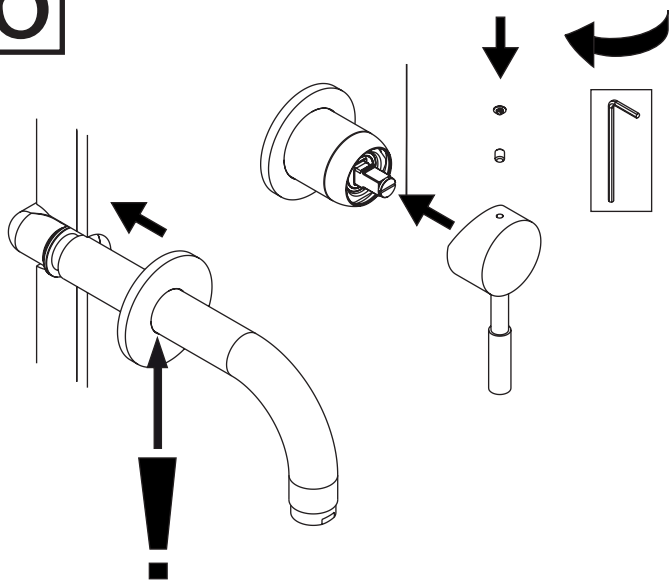

7

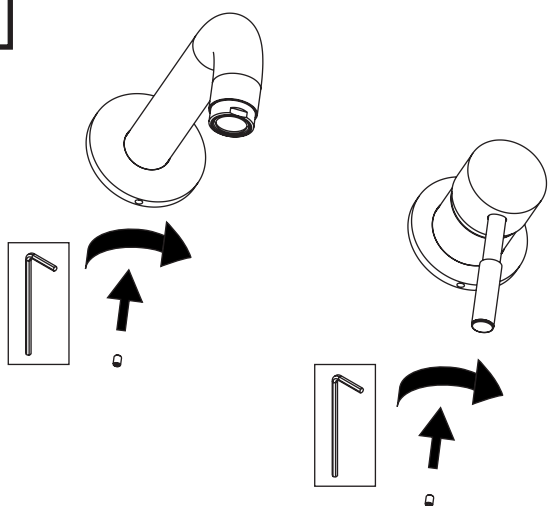

**BOCCHIE SINGOLE >**  
**CONSIDERARE SOLO I PUNTI 5 > 6 > 7**  
**SINGLE WALL SPOUT >**  
**STEPS TO CONSIDER ONLY 5 > 6 > 7**

12200

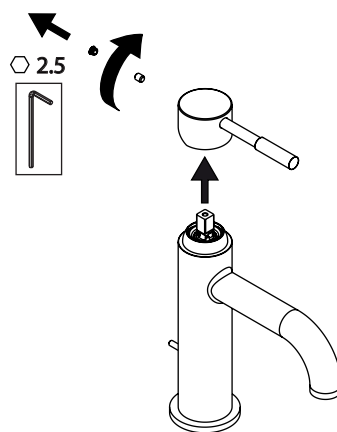
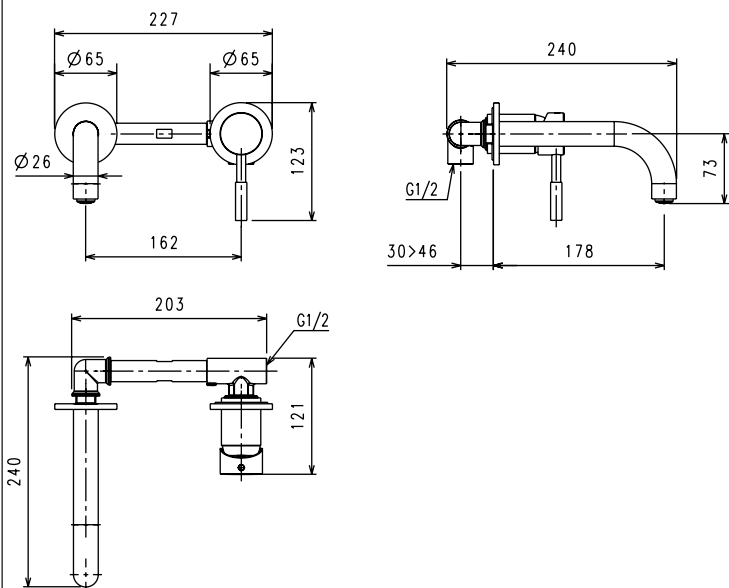

SOSTITUZIONE DELLA LEVA DI COMANDO  
REPLACEMENT OF LEVER MOTION

12144

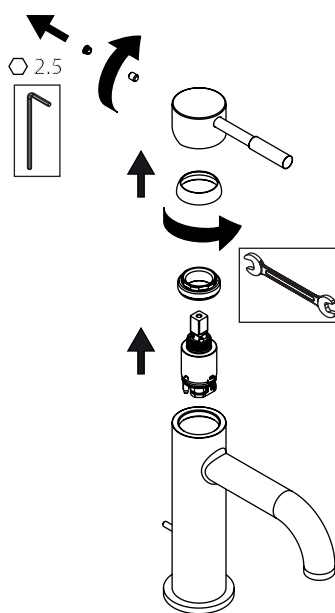
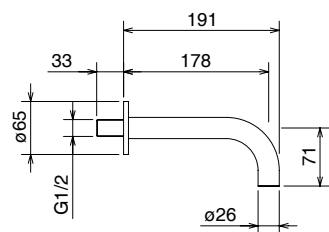

SOSTITUZIONE DELLA CARTUCCIA  
REPLACEMENT OF CARTRIDGE

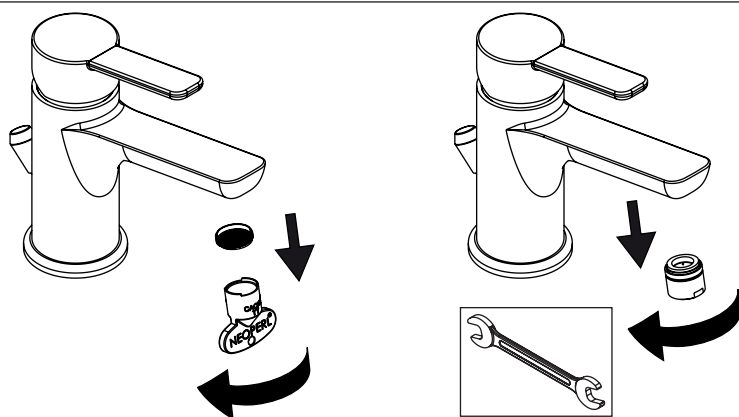

> IN CASO DI SCARSO FLUSSO PROVARE A RIPULIRE L' AERATORE SOTTO GETTO ACQUA CORRENTE O ARIA E RIMONTARE SU CORPO  
> IN CASE OF REDUCED FLOW, TRY TO REMOVE THE AERATOR, RINSE IT WELL UNDER RUNNING WATER AND RE-ASSEMBLE ON THE SPOUT

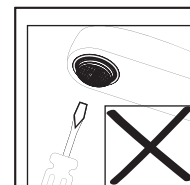
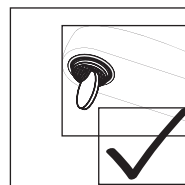
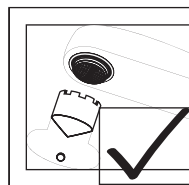

SOSTITUZIONE - PULIZIA AERATORE  
REPLACEMENT - CLEANING AERATOR

**FUNZIONAMENTO DEL MISCELATORE / OPERATION OF THE MIXER**

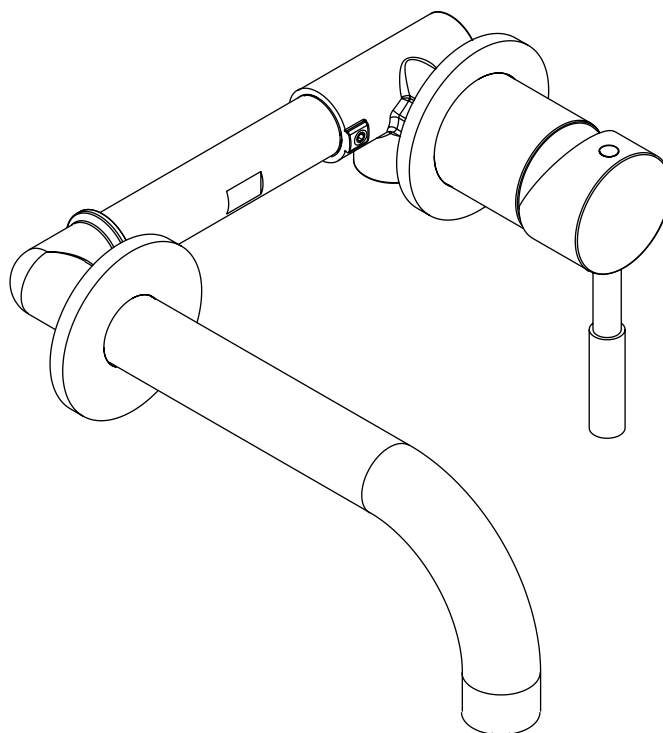
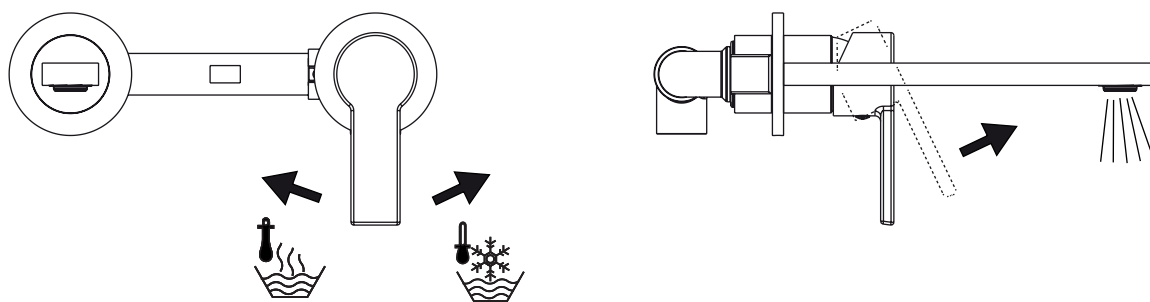

**DOMANDE E RISPOSTE / FAQ**

GUASTO >	CAUSA >	SOLUZIONE POSSIBILE >
SCARSITA' D' ACQUA	FILTRO AERATORE INTASATO DOCETTA CON GETTI INTASATI FLESSIBILI COLLEGATI NON BENE	PULIRE AERATORE O SOSTITUIRLO PULIRE GETTI DOCETTA CON UN DITO RIFARE IL COLLEGAMENTO DEI FLESSIBILI
MISCELATORE DURO	CARTUCCIA DIFETTOSA	SOSTITUIRE LA CARTUCCIA
MISCELATORE GOCCIOLA	CARTUCCIA DIFETTOSA	SOSTITUIRE LA CARTUCCIA
PROBLEM >	POSSIBLE REASON >	ACTION >
INSUFFICIENT FLOW	DEBRITS OR LIMESTONE IN AERATOR HANDSHOWER NOOZLE STUCK OR CLOSED SUPPLY HOSES NON CONNECTED	REMOVE AND REPLACE AERATOR CLEAN THE SHOWER NOOZLES BY RUBBING THEM WITH FINGERS DISCONNECT AND CONNECT AGAIN
LEVER HARD TO OPERATE	DEFECTIVE CARTRIDGE	REPLACE CARTRIDGE
LEAKAGE	DEFECTIVE CARTRIDGE	REPLACE CARTRIDGE

**SMALTIMENTO DEL PRODOTTO >**

NON DISPERDERE NELL' AMBIENTE PER IL CORRETTO SMALTIMENTO DEL PRODOTTO, FARE RIFERIMENTO ALLA NORMATIVA VIGENTE NEL PAESE IN CUI SI VIVE. CONTATTARE LA DISCARICA PIU' VICINA PER MAGGIORI INFORMAZIONI.  
DISPOSAL OF THE ITEM >  
NOT DISPERSE IN NATURE FOR A CORRECT DISPOSAL OF THE ITEM, PLEASE REFER TO THE SPECIFIC RULES OF YOUR COUNTRY THE APPOINTED OFFICE IN YOUR AREA FOR DETAILS.

> MONTAGGIO, USO E MANUTENZIONE - LEGGERE ATTENTAMENTE PRIMA DELL' INSTALLAZIONE - CONSERVARE  
> ASSEMBLY, USE AND MAINTENANCE INSTRUCTIONS - READ CAREFULLY BEFORE INSTALLING - TO PRESERVE